

Product Features

- ✧ FP laser transmitter and PIN photo-detector
- ✧ Dual Data-rate of 1.25Gbps Operation
- ✧ Up to 2KM transmission distance on 50& 62.5/125μm MMF
- ✧ Compliant with SFP MSA and SFF-8472 with duplex LC receptacle
- ✧ Digital Diagnostic Monitor Interface
- ✧ Very low EMI and excellent ESD protection
- ✧ +3.3V single power supply
- ✧ Compatible with RoHS
- ✧ Operating case temperature Commercial: 0°C to +70°C / Extended: -10°C to +80°C / Industrial: -40°C to +85°C

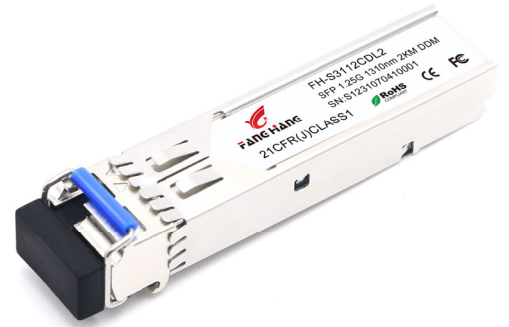

Applications

- ✧ Gigabit Ethernet
- ✧ Fiber Channel
- ✧ Switch to Switch interface
- ✧ Switched backplane applications
- ✧ Router/Server interface
- ✧ Other optical transmission systems

Ordering Information

Part Number	Output Power	Rec. Sens	Data Rate	Wavelength	Distance
<i>FH-S3112CDL2</i>	-9 ~ -3db	-22db	1.25/1.0625Gbps	850/1310nm	2KM
<i>FH-S3112EDL2</i>	-9 ~ -3db	-22db	1.25/1.0625Gbps	850/1310nm	2KM
<i>FH-S3112IDL2</i>	-9 ~ -3db	-22db	1.25/1.0625Gbps	850/1310nm	2KM

General

FH-S3112CDL2 SFP transceivers are high performance, cost effective modules supporting dual data-rate of 1.25Gbps/1.0625Gbps and 2km transmission distance with MMF.

The transceiver consists of three sections: a FP laser transmitter, a PIN photodiode integrated with a trans-impedance preamplifier (TIA) and MCU control unit. All modules satisfy class I laser safety requirements. Transceivers are compatible with SFP Multi-Source Agreement (MSA) and SFF-8472. For further information, please refer to SFP MSA

Absolute Maximum Ratings

Parameter	Symbol	Min.	Max.	Unit	Note
Supply Voltage	Vcc	-0.5	3.6	V	
Storage Temperature		-40	85	°C	
Relative Humidity		5	85	%	

Note: Stress in excess of the maximum absolute ratings can cause permanent damage to the module

General Operating Characteristics

Parameter	Symbol	Min.	Typ.	Max.	Unit	Notes
Data Rate	Gigabit Ethernet		1.25		Gb/s	
	Fiber Channel		1.0625			
Supply Voltage	Vcc	3.1	3.3	3.5	V	
Supply Current	Icc			220	mA	
Operating Case Temperature	Tc	0		70	°C	
		-10		80		
		-45		85		

Electrical Input/Output Characteristics

Parameter	Symbol	Min.	Typical	Max.	Unit	Notes
Transmitter						
Diff. Input Voltage Swing		300		1800	mVpp	1
Tx Disable Input	H	V _{IH}	2.0	V _{CC} +0.3	V	
	L	V _{IL}	0	0.8		
Tx Fault Output	H	V _{OH}	2.0	V _{CC} +0.3	V	2
	L	V _{OL}	0	0.8		
Input Diff. Impedance	Z _{in}		100		Ω	
Receiver						
Diff. Output Voltage Swing		400		1000	mVpp	3
Rx LOS Output	H	V _{OH}	2.0	V _{CC} +0.3	V	2
	L	V _{OL}	0	0.8		

Note 1) TD+/- are internally AC coupled with 100Ω differential termination inside the module.

2) Tx Fault and Rx LOS are open collector outputs, which should be pulled up with 4.7k to 10kΩ resistors on the host board. Pull up voltage between 2.0V and V_{CC}+0.3V.

3) RD+/- outputs are internally AC coupled, and should be terminated with 100Ω (differential) at the user SERDES.

Optical Characteristics

Parameter	Symbol	Min.	Typical	Max.	Unit	Notes
Transmitter						
Ave. Output Power (Enable)	Po	-9		-3	dBm	1
Extinction Ratio	ER	9			dB	1
Rise/Fall Time (20%-80%)	Tr-Tf			0.26	ns	2
Wavelength Range		1270		1360	nm	
Spectral Width (RMS)				4	nm	
Output Optical Eye	Compliant with IEEE802.3 z (class 1 user safety)					
Receiver						
Operating Wavelength		1270		1610	nm	
Sensitivity	Pimin			-22	dBm	3
Min. Overload	Pimax	-3			dBm	3
LOS Assert	Pa	-35			dBm	
LOS De-assert	Pd			-23	dBm	
LOS Hysteresis	Pd-Pa	0.5		6	dB	

Note 1) Measured at 1250 Mb/s with PRBS 223 – 1 NRZ test pattern.

2) Unfiltered, measured with a PRBS 223-1 test pattern @1.25Gbps

3) Measured at 1250 Mb/s with PRBS 223 – 1 NRZ test pattern for BER < 1x10⁻¹²

Diagnostics

Parameter	Range	Unit	Accuracy	Calibration
Temperature	0 to +70 -40 to +85	°C	±3°C	Internal/ External
Voltage	3.0 to 3.6	V	±3%	Internal/ External
Bias Current	2 to 80	mA	±10%	Internal/ External
TX Power	-12 to -1	dBm	±3dB	Internal/ External
RX Power	-25 to 0	dBm	±3dB	Internal/ External

Pin Definitions And Functions

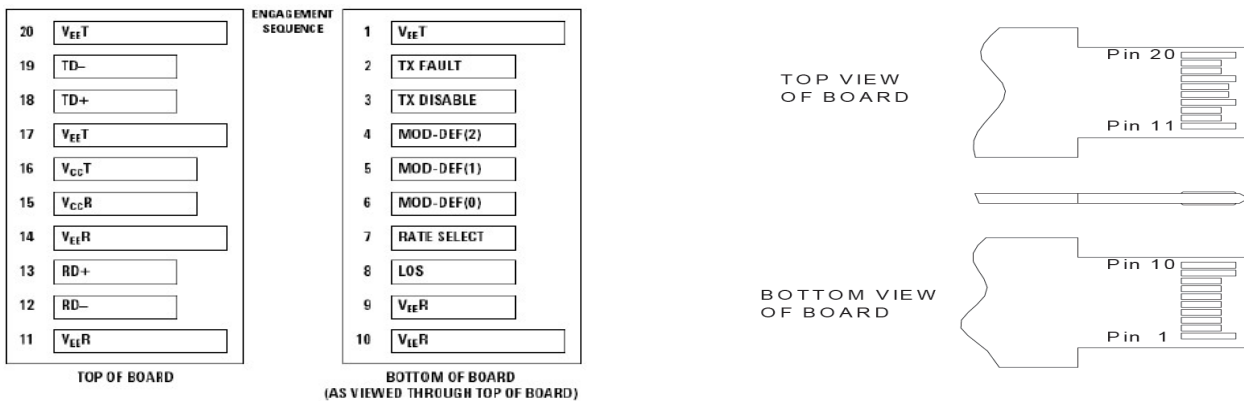

PIN	Name	Function	Notes
1	V _{EE} T	Tx ground	
2	Tx Fault	Tx fault indication, Open Collector Output, active "H"	1
3	Tx Disable	LVTTTL Input, internal pull-up, Tx disabled on "H"	2
4	MOD-DEF2	2 wire serial interface data input/output (SDA)	3
5	MOD-DEF1	2 wire serial interface clock input (SCL)	3
6	MOD-DEF0	Model present indication	3
7	Rate select	No connection	
8	LOS	Rx loss of signal, Open Collector Output, active "H"	4
9	V _{EE} R	Rx ground	

Functional Diagram

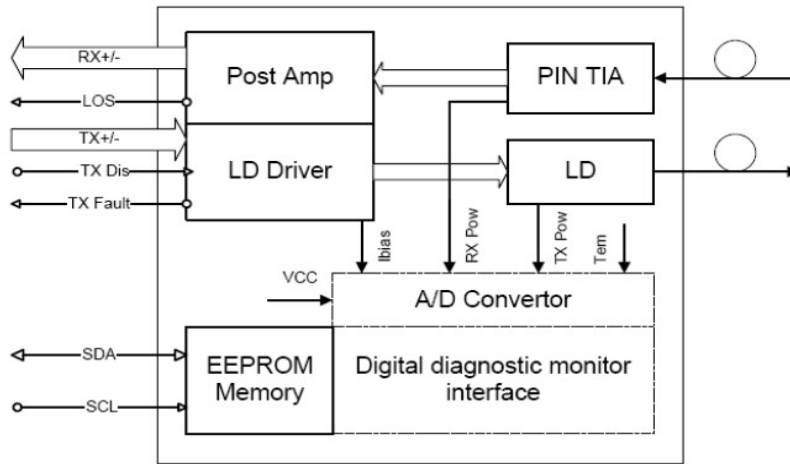

Typical Interface Circuit

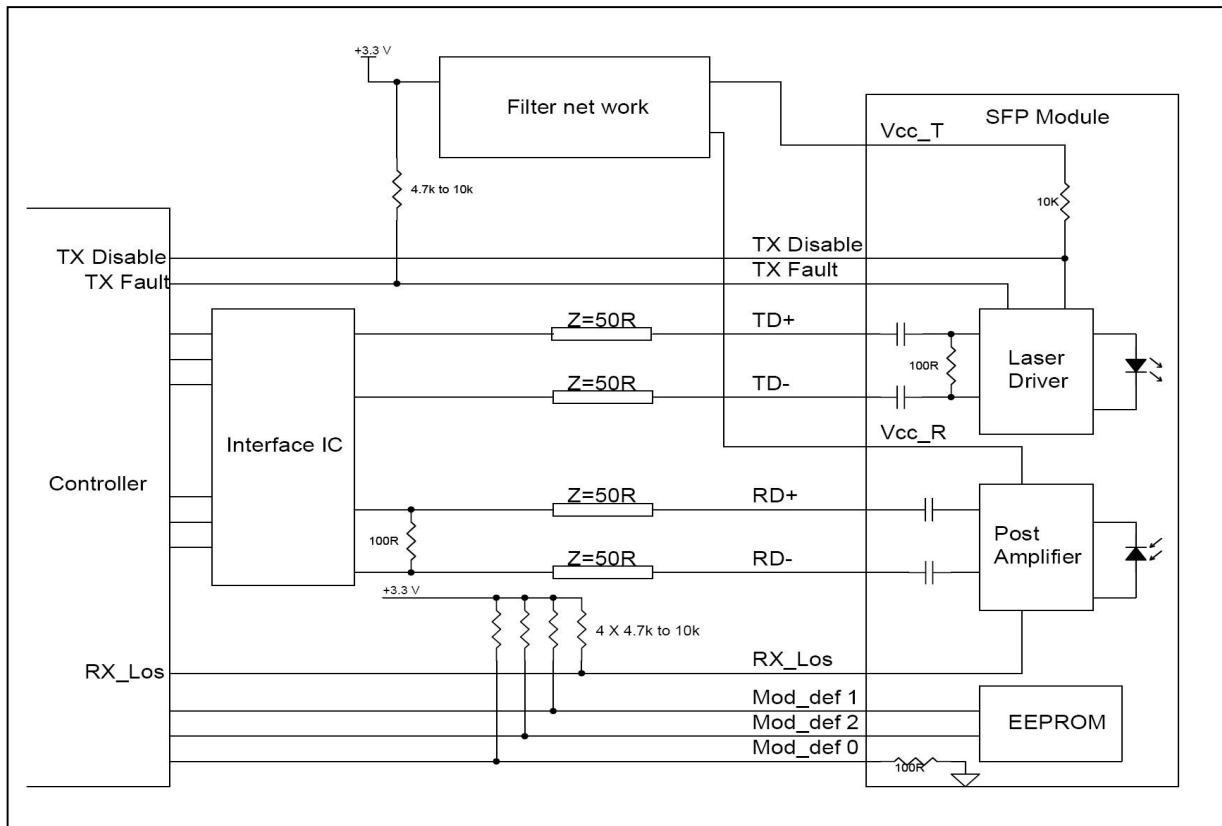

Package Dimensions

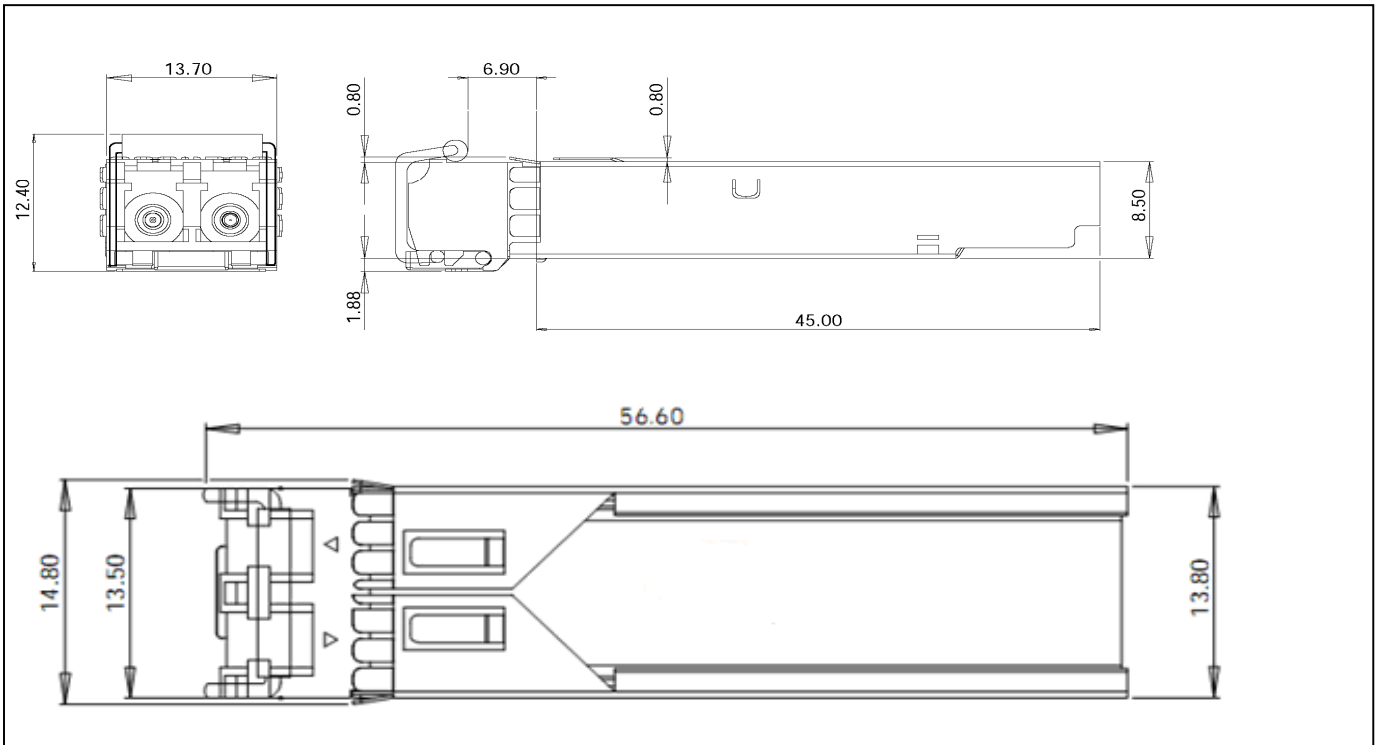

For More Information

FANG HANG TECH LIMITED

Add: Room 908 Jinyuan Building, 28 Bulong Rd, Longgang District, Shenzhen China

Tel: +86-755-89584520

Fax: +86-755-89584520

sales@fanghangtech.com

www.fanghangtech.com